

Exalto Wipercontrol

For 2 to 5 wipers

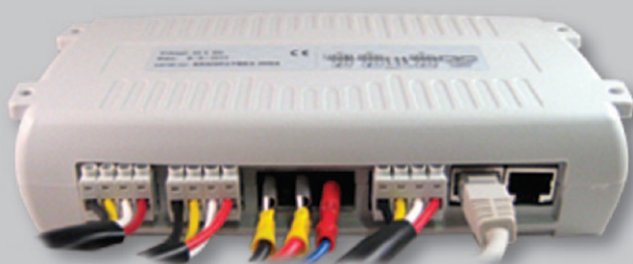

Cat.no.: 21021224 • 21031224 • 21041224 • 21051224

Contents

- 1 General** 3
 - 1.1 Features 3
 - 1.2 Scope of supply 3

- 2 Push button functions** 4

- 3 Operating Mode** 4

- 4 Wipe / Wash program** 5

- 5 Troubleshooting** 5
 - 5.1 Wiper fault 5
 - 5.2 Communication error 6

- 6 Power supply** 6

- 7 System configuration** 6

- 8 System Wiring (2 and 3 wipers)** 7

- 9 System wiring (4 and 5 wipers)** 8

- 10 Relaisbox connections** 9
 - 10.1 Recommended cable sizes 9

- 11 Controlpanel dimensions** 10

- 12 Cut out size of panel** 10

- 13 Relais box dimensions** 10

- 12 Technical Data** 11

1 General

The Exalto Wipercontrol is a microcontroller-based wiper control system for up to 5 wiper motors; it provides all the functions for optimal windscreen cleaning. The control panel is connected to relais box by one serial cable (CAN BUS CABLE) with two 8 pole plugs. Every unit has two plugs (in parallel) and one or both can be used.

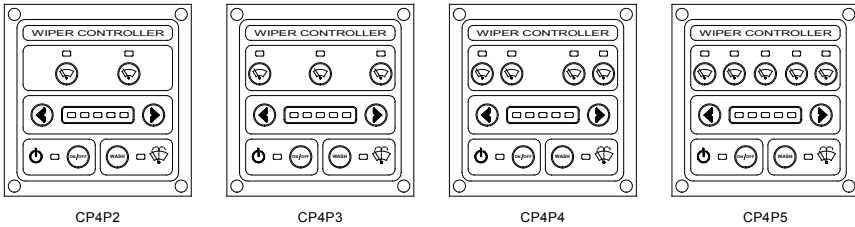

1.1 Features

- Multi voltage supply: 12V - 24V
- Fit for any d.c. motors (see output current) and for any kind of parking switch
- Activates/deactivates each wiper one by one
- Synchronization in each selected mode
- Three (four if one speed motors) intermittent settings
- Perfect self parking position due to “dynamic brake”
- Wipe/wash program
- Easy to install and to use
- Reliable

1.2 Scope of supply

- One controlpanel
- One Relais box
- One cable for can bus connection (standard 5 meters)
- 4 poles female connectors for motor connections (one for each motor)
- One female 6,3 mm fast-on terminal for washing pump connection
- Two (or four if more than 3 wipers) female 9,5 mm fast-on terminals for power supply connection
- User manual

2 Push button functions

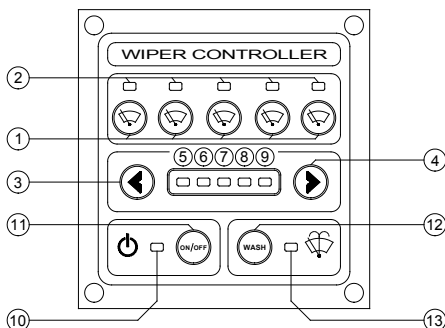

- 1 – single wiper ON/OFF button
- 2 – single wiper ON/OFF and fault led
- 3 – decrease speed / increase delay in intermittent mode
- 4 – increase speed / decrease intermittent delay
- 5,6,7,8,9 – selected mode led bar
- 10 – General ON/OFF led
- 11 – General ON/OFF button
- 12 – Wash cycle button
- 13 – Wash cycle signalling led

3 Operating mode

The available operating mode depends on the number of the motor's speed.

If using 2 speed motors:

SPEED BAR	WAITING TIME	MODE
All leds OFF	-	Stand-by
Led 5 ON	8 seconds	Intermittent
Led 5+6 ON	4 seconds	Intermittent
Led 5+6+7 ON	2 seconds	Intermittent
Led 5+6+7+8 ON	-	Continuous (low speed)
Led 5+6+7+8+9 ON	-	Continuous (high speed)

5.2 Communication error

A shifting effect of the mode bar led indicates that the control panel can't communicate with the relais box; this may happen if the flat cable is damaged / improperly connected or if there is a problem with the can bus terminations.

6 Power supply

The EXALTO WIPER CONTROL will operate correctly if powered from 10V to 30V DC. Insert the motor connectors BEFORE applying power supply. When powered, the EXALTO WIPER CONTROL will execute a lamp test and then will go to stand-by mode.

7 System configuration

The EXALTO WIPERCONTROL can handle up to 5 wipers.
The following configurations are available:

No. of installed wipers	Control panel	Relais box
2	CP4P2	SRM2P
3	CP4P3	SRM3P
4	CP4P4	SRM4P
5	CP4P5	SRM5P

If you need two or more control stations, other control panels can be connected via CAN BUS by the 8 poles connectors (8 poles plug). **It's recommended to connect a control panel to a relais box and not to another control panel. Connect a control panel directly to another control panel only if there is no other possibility.**

8 System wiring (2 and 3 wipers)

IMPORTANT: protect the power supply line(s) by a thermal/magnetic circuit breaker. Thermal/magnetic circuit breaker and the cables diameter must be sized according to the motor consumption and the regulations.

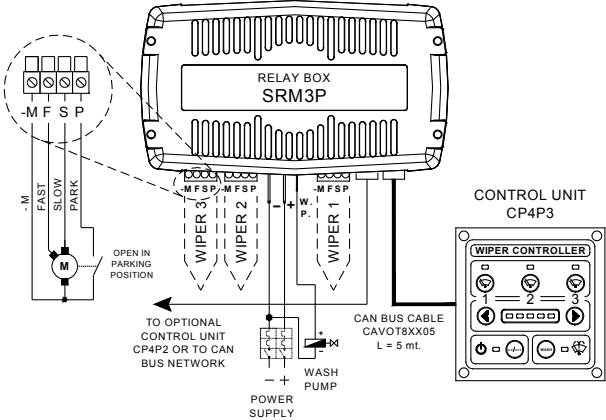
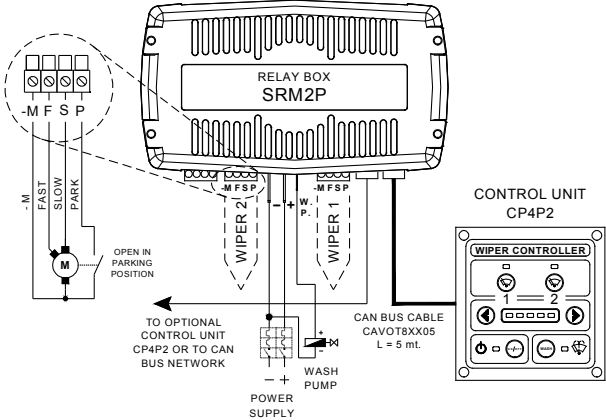

9 System wiring (4 and 5 wipers)

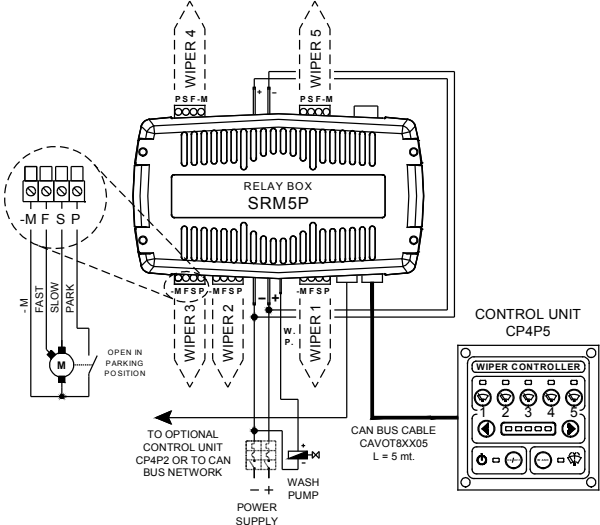
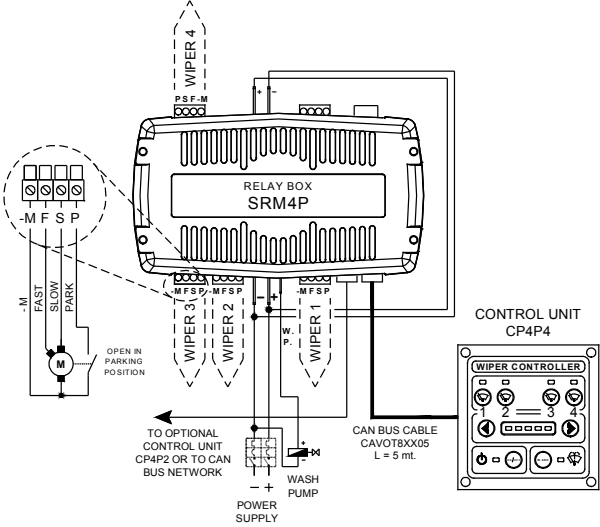

10 Relais box connections

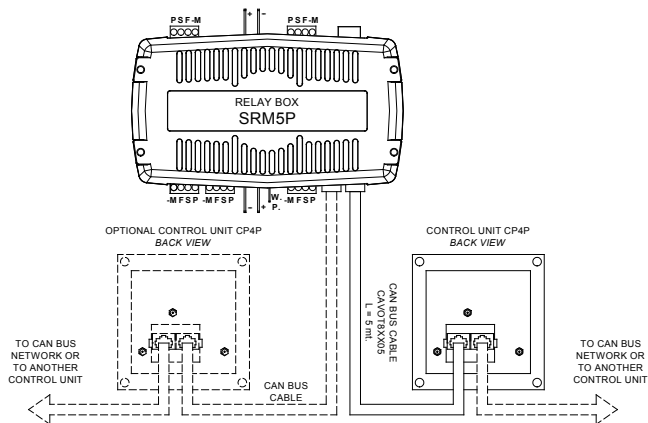

Function	Code	Motorcode	Cable colour
High speed	FAST	53b	White
Low speed	SLOW	53	Yellow
Min/earth	-M	31b	Black*
Park	PARK	53a	Red

* With Exalto motor also connect blue wire 53e to -M

10.1 Recommended Cable sizes

Amperage	Max length	Min Diameter
0.1-2.5	10 m	2.5 mm ²
2.6-4.0	10 m	4.0 mm ²
4.1-8.0	10 m	6.0 mm ²

11 Control panel dimensions

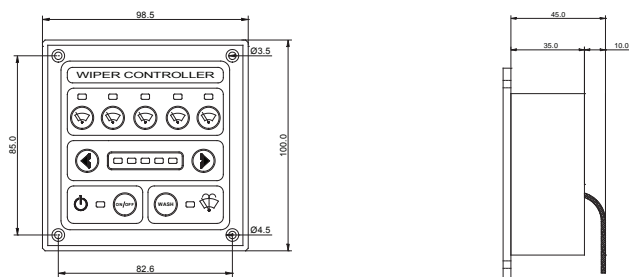

12 Cut out size of panel

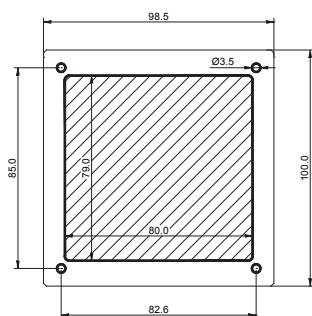

13 Relais box dimensions

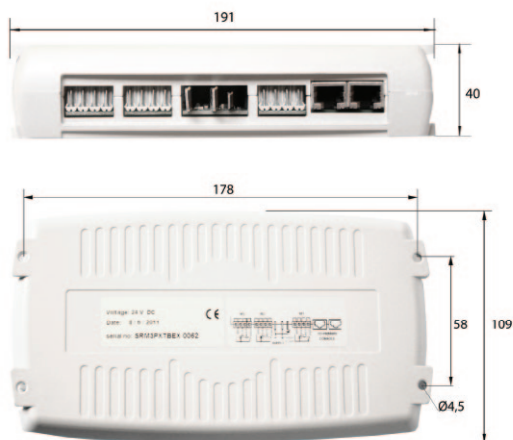

14 Technical data

EXALTO WIPER CONTROL SYSTEM			
Voltage supply	10V to 30V DC		
Internal fuses	12A self-resetting fuse for each motor		
Stand-by current	Less than 70 mA at 10V and less than 40 mA at 30V		
Protections	Polarity inversion		
Motors- output currents	Single or double speed – each motor 12 Amps max.		
Inputs	From 2 to 5 parking switches (open in park position)		
Outputs	From 2 to 5 SLOW speed I _{max} = 12A From 2 to 5 HIGH speed (if using two speed motors) I _{max} = 12A 1 wash pump (positive pole) SLOW I _{max} = 1A		
Functions	3 or 4 intermittent settings 1 or 2 continuous speeds (slow and high speed) Wash / wipe program		
Connections	Relais box SRM2/3P	Relais box SRM4/5P	Control panel CP4PX
	2 or 3 connectors with 4 poles no.2 - male 9,5 mm fast-on no.1 – male 6,3 mm fast-on no.2 connectors (jack) with 8 poles (can bus network)	4 or 5 connectors with 4 poles no.4 - male 9,5 mm fast-on no.1 – male 6,3 mm fast-on no.2 connectors (jack) with 8 poles (can bus network)	2 connectors with 8 poles (can bus network)
Case	Grey ABS		Metal case Frontal panel protection IP65
Working temperature	-25 °C / +50 °C		
Storage temperature	-30 °C / +80 °C		



All the normal precautions and the technical information contained in this manual must be used for a proper installation and use of the products. Exalto BV is not responsible of any damage caused by improper use of the products. Warranty will not cover any damage caused by improper use of the products. The information contained herein is subject to change without notice. EXALTO shall not be liable for technical or editorial errors or omissions contained herein.

Exalto B.V.

- Postbus 40
3370 AA Hardinxveld-Giessendam
Nederland
- **T** +31 (0)184 615 800
- **F** +31 (0)184 618 200
- **E** wipers@exalto.com
- **I** www.exaltowipers.com